

## FITTING INSTRUCTION

Clamp mark in acc. with		Cables joining
ISO	PN	
1	L	Left directional lights
2	+	Rear fog lights
3	31	Ground
4	R	Right directional lights
5	58R	Right side parking lights
6	54	Stoptlights
7	58L	Left side parking lights

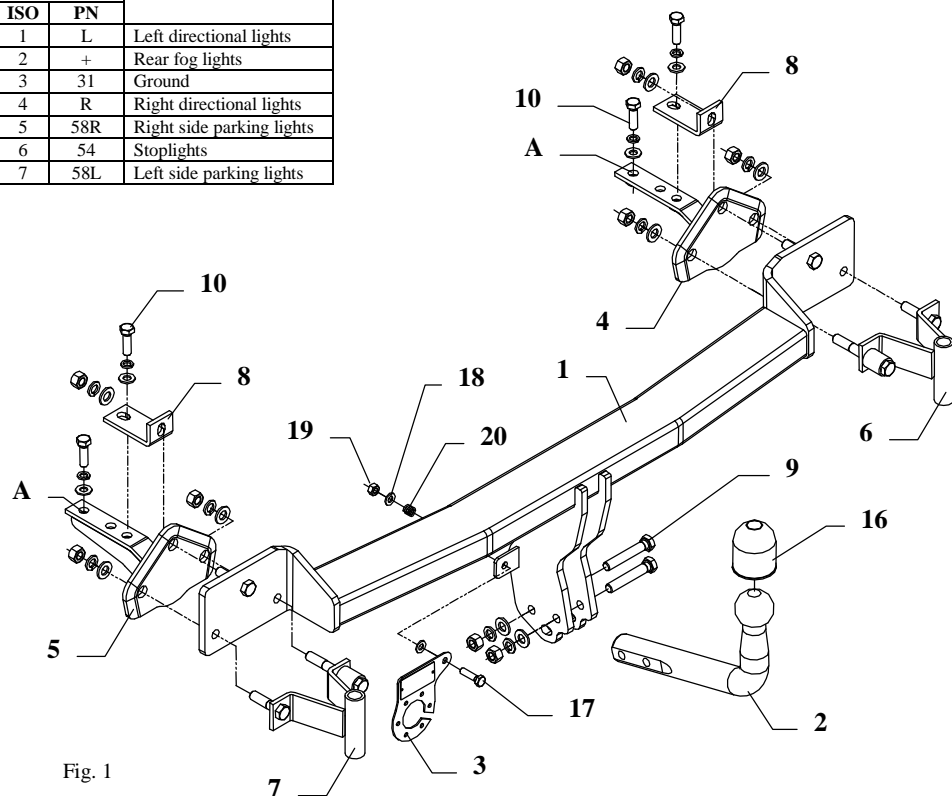

Fig. 1

The towbar is designed to fit in following car:  
**BMW 5 series E39, 4 door**, produced since 12.1995 till 2001 and produced since 2002 till 10.2003, catalogue no. **B08** and is prepared to tow trailers max trailers weight **2100 kg** and max vertical load **90 kg**.

### *From manufacturer*

Thank you for buying our product. Their reliability has been confirmed in many tests. Reliability of towbar depends also on correct assembly and right operation. For this reasons we kindly ask to read carefully this instruction and apply to hints.

*The towbar should be install in points described by a car producer.*

## The instruction of the assembly

1. Disassemble the bumper. Disassemble aluminium element and muffler from the bumper (this part will be not use any more).
2. In aluminium and plastic part of the bumper cut out fragments (as shown on the fig. 2 and 3).
3. In baggage part of the car disassemble covers (rear part and bottom).
4. Insert brackets (pos. 4 and 5) to chassis members (as shown on the fig. 1) and fix loosely through holes (pos. A) using bolts M10x35mm (pos. 10).
5. Fix handles (pos. 6 and 7) to the aluminium part of the bumper and next fix its plastic part.
6. So prepared towbar put to the rear part of car, put side brackets and angle bars (pos. 8) and fix.
7. Fix tow-ball (pos. 2) using bolts M12x70mm (pos. 9) from accessories.
8. Fix the socket plate (pos. 3) as shown on the drawing.
9. Tighten all bolts according to the torque shown in the table.
10. Connect electric wires of 7-poles socket according to the instruction of the car. (Recommend to make at authorized service station).
11. Complete paint layer damaged during installation.

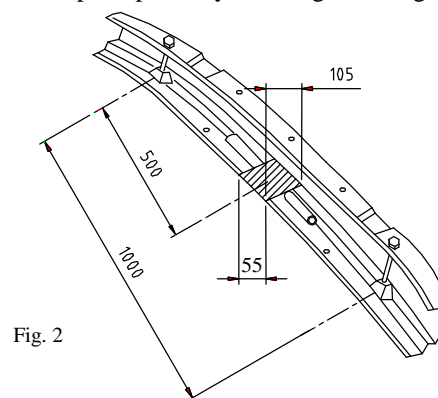

Fig. 2

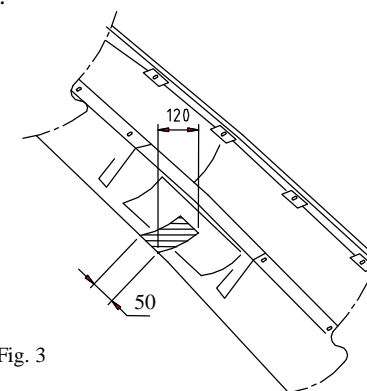

Fig. 3

Torque settings for nuts and bolts (8,8):	
<b>M 8</b> - 25 Nm	<b>M 10</b> - 55 Nm
<b>M 12</b> - 85 Nm	<b>M 14</b> - 135 Nm











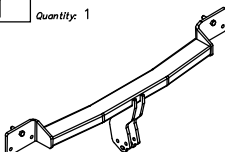
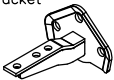

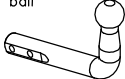
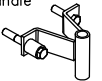

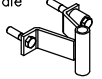

### NOTE

After install the towbar you should get adequate note in registration book (at authorised service station).The car should be equipped with:

- Indicators
- Tow mirrors

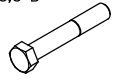
After 1000km of exploitation check all bolts and nuts. The ball of towbar must be always kept clear and conserve with a grease.

## Towbar accessories:

Pos. 1 Name: Main bar Quantity: 1	Pos. 5 Name: Left bracket Quantity: 1	Pos. 10 Name: Bolt 8,8 B Quantity: 4 Dim.: M10x35mm	Pos. 15 Name: Spring washer Quantity: 4 Dim.: $\varnothing$ 10,2 mm
			
Pos. 2 Name: Tow ball Quantity: 1	Pos. 6 Name: Right handle Quantity: 1	Pos. 11 Name: Nut 8 B Quantity: 8 Dim.: M12	Pos. 16 Name: Ball cover Quantity: 1
			
Pos. 3 Name: Socket plate Quantity: 1	Pos. 7 Name: Left handle Quantity: 1	Pos. 12 Name: Plain washer Quantity: 8 Dim.: $\varnothing$ 13 mm	Pos. 17 Name: Bolt 8,8 B Quantity: 1 Dim.: M8x30mm
			
Pos. 4 Name: Right bracket Quantity: 1	Pos. 8 Name: Angle bar Quantity: 2 Dim.: 83x35x6mm	Pos. 13 Name: Plain washer Quantity: 4 Dim.: $\varnothing$ 10,5 mm	Pos. 18 Name: Plain washer Quantity: 2 Dim.: $\varnothing$ 8,5 mm
			
Pos. 9 Name: Bolt 8,8 B Quantity: 2 Dim.: M12x70mm	Pos. 14 Name: Spring washer Quantity: 8 Dim.: $\varnothing$ 12,2 mm	Pos. 19 Name: Nut 8 B Quantity: 1 Dim.: M8	Pos. 20 Name: Spring Quantity: 1
			



## PPUH AUTO-HAK S. J.

Produkcja Zaczepów Kulowych  
Henryk & Zbigniew Nejman  
76-200 SŁUPSK ul. Słoneczna 16K  
tel/fax (059) 8-414-414; 8-414-413  
E-mail: [office@autohak.com.pl](mailto:office@autohak.com.pl)  
[www.autohak.com.pl](http://www.autohak.com.pl)

## Towing hitch (without electric supply)

Class: **A50-X** Cat. no. **B08**

Designed for:

Manufacturer: **BMW**

Model: **SERIES 5 (E39)**

Type: **4door**

produced since 12.1995 till 2001

and since 2002 till 10.2003

Technical data:

**D-value: 10,3 kN**

maximum trailer weight: **2100 kg**

maximum vertical cup load: **90 kg**

Approval number acc. to regulations EKG/ONZ 55.01: **E20-55R-01 1276**

## Foreword

This towbar is designed according to rules of safety traffic regulations. The towing hitch is a safety component and can be install only by qualified personnel. Any alteration or conversion of the towing hitch is prohibited and would lead to cancellation of design certification. Remove insulating compound and underseal from vehicle (if present) in the area of the matting surfaces of the towing hitch.

The vehicle manufacturer's specifications regarding trailer load and max. vertical cup load are decisive for driving, and values for the towing hitch cannot be exceeded.

*D-value formula:*

$$\frac{\text{Max trailer weight [kg]} \times \text{Max vehicle weight [kg]}}{\text{Max trailer weight [kg]} + \text{Max vehicle weight [kg]}} \times \frac{9,81}{1000} = D \text{ [kN]}$$