

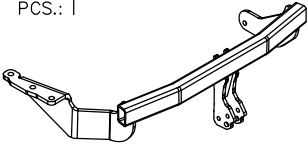

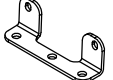







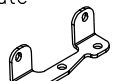

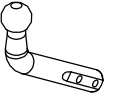
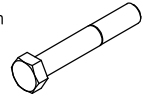
## Towing hitch accessories:

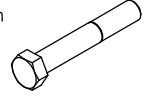
Pos. 1 Main bar PCS.: 1 	Pos. 5 Right fish-plate PCS.: 1 	Pos. 11 Plain washer ø12mm PCS.: 5 
	Pos. 6 Left fish-plate PCS.: 1 	Pos. 12 Plain washer ø10mm PCS.: 10 
Pos. 2 Tow ball PCS.: 1 	Pos. 7 Bolt 8,8 B M12x75mm PCS.: 1 	Pos. 13 Spring washer ø12mm PCS.: 5 
	Pos. 8 Bolt 8,8 B M12x70mm PCS.: 1 	Pos. 14 Spring washer ø10mm PCS.: 10 
Pos. 3 Socket plate PCS.: 1 	Pos. 9 Bolt 8,8 B M12x40mm PCS.: 3 	Pos. 15 Nut 8 B M12 PCS.: 5 
	Pos. 10 Bolt 8,8 B M10x1,25x40mm PCS.: 10 	Pos. 16 Ball cover PCS.: 1 
	Pos. 4 Right bracket PCS.: 1 	

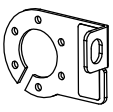

**PPUH AUTO-HAK Sp.J.**

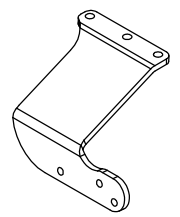
Produkcja Zaczepów Kulowych  
Henryk & Zbigniew Nejman  
76-200 SŁUPSK ul. Słoneczna 16K  
tel/fax (059) 8-414-414; 8-414-413  
E-mail: [office@autohak.com.pl](mailto:office@autohak.com.pl)  
[www.autohak.com.pl](http://www.autohak.com.pl)

## Towing hitch (without electrical set)

Class: **A50-X** Cat. no. **Z38**

Designed for:

**MITSUBISHI OUTLANDER**

**PEUGEOT 4007**

**CITROEN C-CROSSER**

produced since 04.2007

Technical data:

**D-value: 11,0 kN**

maximum trailer weight: **2000 kg**

maximum vertical cup load: **100 kg**

Approval number according to Directive 94/20/EC: **e20\*94/20\*0339\*00**

### NOTE!

**With installed tow ball opening of bottom part of boot door is impossible! Do not open it when tow ball is installed! Before open dismount a tow ball. Additionally stick the supplied information label in visible place, please.**

### Foreword

This towing hitch is designed according to rules of safety traffic regulations. The towing hitch is a safety component and can be install only by qualified personnel. Any alteration or conversion of the towing hitch is prohibited and would lead to cancellation of design certification. Remove insulating compound and underseal from vehicle (if present) in the area of the matting surfaces of the towing hitch. The vehicle manufacturer's specifications regarding trailer load and max. vertical cup load are decisive for driving whereat values for the towing hitch cannot be exceeded.

*D-value formula:*

$$\frac{\text{Max trailer weight [kg]} \times \text{Max vehicle weight [kg]}}{\text{Max trailer weight [kg]} + \text{Max vehicle weight [kg]}} \times \frac{9,81}{1000} = D \text{ [kN]}$$

## FITTING INSTRUCTION

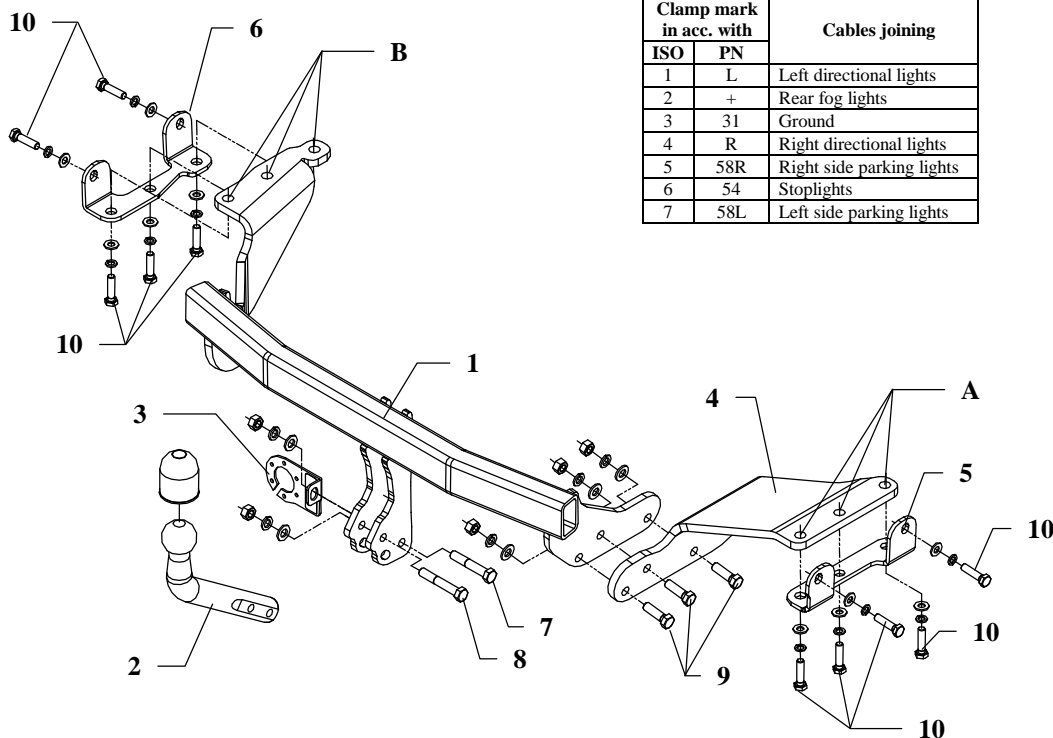

Clamp mark in acc. with		Cables joining
ISO	PN	
1	L	Left directional lights
2	+	Rear fog lights
3	31	Ground
4	R	Right directional lights
5	58R	Right side parking lights
6	54	Stoplights
7	58L	Left side parking lights

This towing hitch is designed to assembly in following cars: **MITSUBISHI OUTLANDER, PEUGEOT 4007, CITROEN C-CROSSER** produced since 04.2007, catalogue no. **Z38** and is prepared to tow trailers max total weight **2000 kg** and max vertical load **100 kg**.

Torque settings for nuts and bolts (8,8):	
<b>M 8</b> - 25 Nm	<b>M 10</b> - 55 Nm
<b>M 12</b> - 85 Nm	<b>M 14</b> - 135 Nm

### From manufacturer

Thank you for buying our product. Their reliability has been confirmed in many tests. Reliability of towing hitch depends also on correct assembly and right operation. For this reasons we kindly ask to read carefully this instruction and apply to hints.

*The towing hitch should be installing in points described by a car producer.*

## The instruction of the assembly

1. Underneath a car disassemble spare wheel unit and unfasten a muffler from last rubber handle.
  2. On the right side, to chassis member fix trough holes A right bracket (pos. 4) with right fish-plate (pos. 5) using bolts M10x1,25x40mm (pos. 10) as shown on figure 1. Next fix fish-plate from side using two bolts M10x1,25x40mm (pos. 10).
  3. In bumper cut out fragment (in axis) according to figure 2.
  4. Put main bar of the towing hitch (pos. 1) to car's chassis and fix as shown in figure 1:
    - to left chassis member through holes B using bolts M10x1,25x40mm (pos. 10) with left fish-plate (pos. 6). Fish-plate fix from side using two bolts M10x1,25x40mm (pos. 10).
    - on the right side to already mounted right bracket (pos. 4) using bolts M12x40mm (pos. 9)
  5. Fix tow-ball (pos. 2) with socket plate (pos. 3) using bolts M12x75mm (pos. 7) and M12x70mm (pos. 8) from accessories.
- IMPORTANT! See note on page 1 of this instruction.**
6. Reassemble spare wheel unit and attach a muffler.
  7. Tighten all bolts according to the torque shown in the table.
  8. Connect electric wires of 7-poles socket according to the instruction of the car. (Recommend to make at authorized service station).
  9. Complete paint layer damaged during installation.

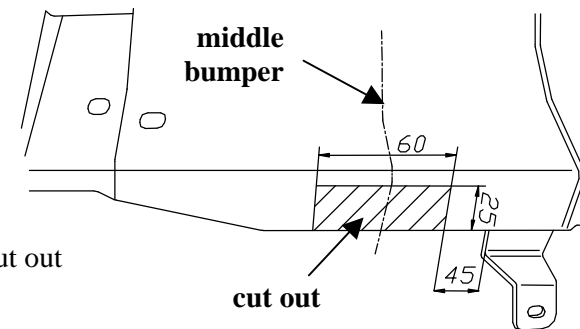

Fig. 2 Bumper's cut out

## NOTE

After install the towing hitch you should get adequate note in registration book (at authorised service station).The car should be equipped with:

- Indicators
- Tow mirrors

After 1000km of exploitation check all bolts and nuts. The ball of towing hitch must be always kept clear and conserve with a grease.